

# BD50

CRAWLER DOZER



## Salient Features :

- Turbo Charged BEML BS6D105-1 Engine
- Spur gear, double reduction Transmission
- Wet clutch steering & brake
- Groove-type Floating Seals



Flywheel horsepower (net) : 67kW (90hp) @ 1750 rpm

Operating mass : 12170 kg  
(with Angle Dozer)

# BD50

[www.bemlindia.in](http://www.bemlindia.in)

# BD50

## CRAWLER DOZER

### Salient Features :

- Diesel Engine : Turbo-charged, Direct-injection system for high fuel efficiency and for cleaner exhaust. Can work up to 4500m altitude without fuel adjustment.
- Main frame and steering case welded into a rigid monoblock construction.
- Wet type main clutch hydraulically boosted and foot controlled for light touch and smooth operation.
- Unit construction of engine, clutch and transmission assemblies for quicker and easier servicing and overhaul.
- Reduced maintenance time and costs as well as extended serviceability of undercarriage assured with floating seals in oil filled rollers, sprockets and idlers.
- Dust seals located between link bushing and pin prevent entry of abrasive dirt or mud and ensure long track life.



### ENGINE

Make	BEML
Model	BS6D 105-1
Type	Water cooled, 4 cycle turbo charged, direct injection diesel engine
No. of Cylinders	6, inline
Bore x Stroke	∅ 105 x 125 mm
Displacement	6490 cc
<b>Horse Power</b>	
Gross Power	74.5 kW (100 hp) @ 1750 rpm
Flywheel power	67 kW (90hp) @ 1750 rpm in accordance with IS : 13116 / ISO : 9249
Maximum torque	47.5 kg-m @ 1100 rpm
<b>Fuel System</b>	
Type	Bosch inline FIP
Governor	Mechanical, all speed control
<b>Lubrication system</b>	
Method	Forced lubrication
Pump	Gear pump
Filter	Spin-on cartridge paper element
Oil Cooler	Water cooled
<b>Cooling system</b>	
Type	Centrifugal water pump, pusher type fan
<b>Air Cleaner</b>	
Type	Dry, horizontal type
<b>Electricals</b>	
Alternator	24 V, 45 A
Starting motor	24 V, 7.5 kW
Battery	2 x 12 V, 150 Ah

### POWER TRAIN

<b>Transmission</b>			
Type	Direct drive		
Main Clutch Type	Wet, double disc spring type with inertia brake, foot operated and hydraulic booster.		
Transmission Type	Spur gear, selective sliding, splash lubricated and hand operated.		
<b>Final Drive</b>			
Type	Spur gear, double reduction		
Reduction ratio	10.07		
Gear Shift	4 forward, 3 reverse		
<b>Travel speeds m/sec (km/h)</b>			
Range	Forward	Drawbarpull (kg)	Reverse
1st	0 - 0.9(0-2.5)	8280	0-0.89(0-3.2)
2nd	0 - 0.98(0-3.5)	5920	0-1.45(0-5.2)
3rd	0 - 1.54(0-5.5)	3770	0-2.24(0-8.0)
4th	0 - 2.63(0-9.4)	2210	

### STANDARD ACCESSORIES

Tachohourmeter	Key switch
Voltmeter	Back - up switch
Engine Oil Pressure Gauge	High water temperature indicator
Water temperature gauge	Light switch
Head lamps & rear lamp	Low engine oil pressure indicator
Charger indicator	4st relay, battery relay
Back - up alarm	Tool kit
24 V, (12 V x 2) 150 Ah batteries	Canvas Canopy
Angle Dozer attachment	

### OPTIONAL ATTACHMENTS

Rake Dozer	Heater with Defroster
Reduced width blade	Multi - shank ripper
Drawbar (fixed type)	Cold start kit
500 mm shoe	FOPS Steel Cabin (400 Kg.)

## HYDRAULIC SYSTEM

### Hydraulic Pump

Type	Gear pump
Capacity	170 ℓ / min @ 1750 rpm
Relief pressure	140 kg / cm <sup>2</sup>

### Hydraulic Cylinders

Type	Double acting piston
Blade lift	2 cylinders
Bore x Stroke	∅ 90 x 883 mm

## UNDER CARRIAGE

Suspension	Semi - rigid equalizer bar type
Track Frame	Box section, high tensile strength steel construction
Track Rollers	5 No. each side
Carrier Rollers	2 No. each side

### Track Shoes

Type	Single grouser
Grouser Height	50 mm
Shoe width	400 mm
No. of shoes	38 on each side
Ground pressure	0.73 kg / cm <sup>2</sup>
Ground contact area	16,700 cm <sup>2</sup>
Gradeability	Longitudinal 30° Side 12°

## BLADE ATTACHMENT

	Angle Dozer	Straight Dozer
Overall length with dozer (mm)	4700	4455
Blade length x height (mm)	3350 x 865	2760 x 990
Max. lift above ground (mm)	1050	930
Max. drop below ground (mm)	380	445
Max. tilt adjustment (mm)	250	250
Max. Angling adjustment (degrees)	25	
Additional ground Pressure (kg / cm <sup>2</sup> )	0.108	0.109

### Mass (kg)

Dozer attachment	1470	1495
Hydraulic control unit	330	330

## OPERATING MASS

Mass of tractor only (including rated capacity of lubricant, coolant and fuel)	10370 kg
--	----------

### DIMENSIONS : in mm

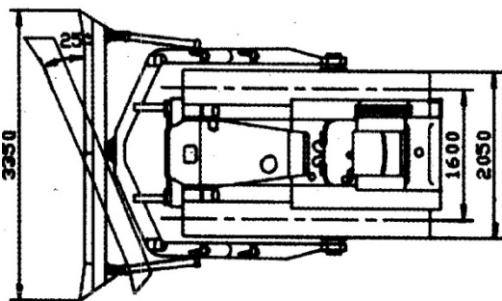

Ground Clearance : 350 mm

Material and specifications are subject to change without notice, Illustrations may include optional equipment & accessories

## STEERING

### Steering Clutch

Type	Dry, multiple disc
Control	Hand operated with spring booster

### Steering Brake

Type	Dry, contracting band
Control	Hand operated

Min. turning radius 2.7 m

## COOLANT AND LUBRICANT CAPACITY (Refill)

System (refilling)	Capacity in ℓ
Cooling System	35
Engine oil pan	24
Fuel Tank	240
Main Clutch	15
Transmission bevel gear case	34
Final Drive (each side)	12
Hydraulic tank	50

## DRAWBAR PULL Vs TRAVEL SPEED

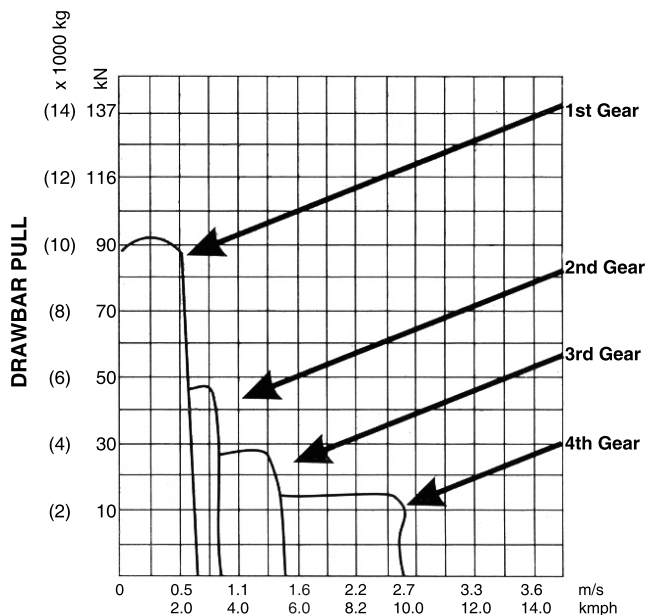

### TRAVEL SPEED

Note : Usable drawbar pull will depend upon the traction and weight of the equipped tractor.

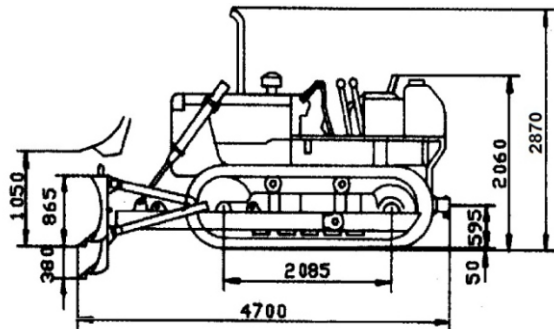

बी ई एम एल लिमिटेड

**BEML LIMITED**

Schedule 'A' Company under Ministry of Defence, Govt. of India

**Business Network**

**Corporate Office**

BEML Soudha, 23/1, 4th Main,  
S.R. Nagar, Bangalore – 560 027

T +91 80 22963240, 22963250

F +91 80 22963278/516/280/164

E-mail: office@cpd.beml.co.in  
corpcomm@beml.co.in

**International Business Division**

Flat No. E,F,G, H, 'Vandana' 11<sup>th</sup> Floor,  
11, Tolstoy Marg, Connaught Place  
New Delhi – 110 001

T + 91 11 23316500  
F + 91 11 23325085

E-mail: office@export.beml.co.in

**Marketing Division**

5th Floor, Unity Building,  
J.C. Road, Bangalore – 560 002

T + 91 80 22963501/02/07/510/540

F + 91 80 22963541

E-mail: m@beml.co.in  
mmd@beml.co.in

## REGIONAL OFFICES

### Bangalore

3rd Floor, Unity Building, J. C. Road,  
Bangalore - 560 002  
Karnataka

T +91 80 2296 3524  
T +91 97413 51588  
E-mail: mg@beml.co.in

### Bilaspur

1-A, Industrial Area, Sector-C, Sirgitti,  
Bilaspur - 495 223.  
Chhattisgarh

T + 91 7752 252745, 252598  
F + 91 7752 252065  
E-mail: mv@beml.co.in

### Neyveli

F-4, Dr. Rajendraprasad Road,  
Block-27, Neyveli, - 607 803  
Tamil Nadu

T/F + 91 4142 268517  
T + 91 4142 265517 / 229392  
E-mail: ma@beml.co.in

### Dhanbad

Mouza - Kangalo, Amaghata,  
Govindpur, KG Ashram Post, Dhanbad  
Jharkhand - 828 109

T + 91 94711 92023  
E-mail: mf@beml.co.in

### Hyderabad

3-6-114, Street No.18, Himayat Nagar,  
Hyderabad - 500 029  
Telangana

T + 91 40 2322 7032 / 94907 93117  
F + 91 40 23221794  
E-mail: hyderabad@rm.beml.co.in

### Kolkata

35/1A, Taratala Road,  
Kolkata - 700 088.  
West Bengal

T + 91 33 2401 5286 / 87 / 98 / 99  
F + 91 33 2401 5288  
E-mail: kolkata@rm.beml.co.in

### Mumbai

32A, Bazar Road,  
Near Jain Mandir, Bandra (West), Mumbai,  
Maharashtra - 400 050

T + 91 22 26431875 / 26435875  
F + 91 22 26423928  
E-mail: mumbai@rm.beml.co.in

### Nagpur

No 33, Cement Road,  
Shivaji Nagar,  
Nagpur - 440 010, Maharashtra.

T + 91 712 2248435 / 2248343  
F + 91 712 2249997  
E-mail: nagpur@rm.beml.co.in

### New Delhi

Flat E,F,G,H, 'Vandana', 11th Floor,  
11, Tolstoy Marg, Connaught Place,  
New Delhi - 110 001

T + 91 11 2344 3511 / 3528 / 2331 6500  
F + 91 11 2332 5085  
E-mail: mlm@rm.beml.co.in

### Ranchi

206/D-1, Bhagirathi, (Behind NCC Campus)  
Rameshwaram Colony, Bariatu Road,  
Ranchi, Jharkhand - 834 009

T + 91 651 2540710 / 94311 08531  
E-mail: ranchi@rm.beml.co.in

### Sambalpur

BEML Complex, NH-6, Panchagachhia,  
Baraipalli Post, Sambalpur 768 006  
Odisha.

T + 91 663 2521604 / 2521389  
E-mail: mb@beml.co.in

### Singrauli

PB No. 5, Jhingurdha Colliery,  
Singrauli - 486 889  
Madhya Pradesh.

T + 91 7805 272668 / 272318  
F + 91 7805 272282  
E-mail: singrauli@rm.beml.co.in

## ACTIVITY CENTRES

### Bhopal

Ground Floor, Hall No.1, Chittod Complex, Zone-1,  
Maharanapratap Nagar (MP Nagar), Bhopal - 462 011

T + 91 755 2550711 / 8989459753

### Panjim

BEML Limited, 5/4, Victor Building, Fontanhas, Mala,  
Panjim - 403 001, Goa

T +91 832 2225135 / 77986 87178  
E-mail: goa@rm.beml.co.in

### Itanagar

C/o. Tobom Riba, H-Sector, Papum  
Itanagar – 791 113, Arunachal Pradesh

T + 91 94029 34205 / 88372 15852  
E-mail: mcgi@beml.co.in

### Kochi

No. 39/2122, Chittod Road, Ernakulam South,  
Kochi – 682 016

T + 91 484 2375138  
E-mail: kochi@rm.beml.co.in

### Maihar

Maihar, Madhya Pradesh

Mob: +91 79875 53768

### Silapathar

Silapathar: Surya Vatika, Amritpur, Silapathar, Assam - 787 059

T +91 95311 29059

### Visakhapatnam

No. 8-45-11, 4th Lane, Vidyannagar China Waltair Colony  
Visakhapatnam - 530 003, Andhra Pradesh

T/F +91 891 2754608 / 83320 54590  
E-mail: vizag@rm.beml.co.in

## DISTRICT OFFICES

### Ahmedabad

99/100, BEML HOUSE, 2nd Street,  
Azad Society, Ambawadi,  
Ahmedabad - 380 015, Gujarat

T + 91 79 26445523 / 94264 13620  
F + 91 79 26423950  
E-mail: ahmedabad@rm.beml.co.in

### Asansol

3, Burnpur Road,  
Asansol - 713 304  
West Bengal

T + 91 341 2252480  
F + 91 341 2250601  
E-mail: asansol@rm.beml.co.in

### Bacheli

Behind Central Stores of NMDC Ltd.,  
Depot 5, Bacheli - 494 553.  
Chhattisgarh

T/F + 91 7857 230005  
E-mail: bacheli@rm.beml.co.in

### Bhilai

Room no 22/C, BSP Expansion Building,  
Near Ispat Bhavan, Bhilai 490 001, Chhattisgarh

T + 91 788 2223880  
F + 91 788 2221652  
E-mail: mnboffice@beml.co.in

### Bhubaneswar

252/A, Lewis Road  
Bhubaneswar - 751 014  
Odisha

T + 91 674 2434427 / 99373 83950  
E-mail: mbb@beml.co.in

### Chandrapur

Mamidwar, Tiles Factory Compound  
Chugus Road, Padoli  
Chandrapur - 442 406 Maharashtra

T + 91 7172 287230  
F + 91 7172 287560  
E-mail: mnc@beml.co.in

### Chennai

Flat No. 10, Supriya Estates,  
No.3, Sterling Road, Nungambakkam,  
Chennai - 600 034, Tamil Nadu,

T + 91 44 28220844  
F + 91 44 28257319  
E-mail: chennai@rm.beml.co.in

### Guwahati

No.11, Ward 43, Hengrabari Road,  
Ganesh Puri, Dispur,  
Guwahati - 781 006 Assam

T + 91 361 2232966  
F + 91 361 2232967  
E-mail: guwahati@rm.beml.co.in

### Hospet

No.1431, Manjunatha Complex,  
Bhagat Singh Nagar, Opp. KSSIDC Indl. Estate,  
Dam Road, Hospet - 583 203, Karnataka

T/F + 91 8394 230172  
E-mail: hospet@rm.beml.co.in

### Jammu

62C, Block D/C, Gandhi Nagar,  
Jammu tawi - 180 004  
Jammu and Kashmir

T + 91 191 2459 437  
F + 91 191 2430 447  
E-mail: mlj@beml.co.in

### Kothagudem

Old Project Planning Department,  
Near SCCL Corporate Office,  
Kothagudem - 507 101, Telangana

T + 91 8744 245572  
F + 91 8744 245530  
E-mail: kothagudem@rm.beml.co.in

### Leh

174-B, (Near Royal Enfield Showroom),  
Housing Colony, Leh, Ladakh -194 101

T + 91 1982 258828 / 94198 71008  
E-mail: ml@beml.co.in

### Ramagundam

Near SCCL TTC, Jawahar Nagar,  
Behind CISF Camp, Godavarikhani - 505 209.  
Peddapalli Dist., Telangana

T + 91 8728 248299 / 94408 58441  
E-mail: mhr@beml.co.in

### Udaipur

20-B, Uchhab Bhavan, Bedla Road,  
Fatehpura, Udaipur - 313 001.  
Rajasthan

T + 91 294 2452054  
E-mail: mwu@beml.co.in

[www.bemlindia.in](http://www.bemlindia.in)

Represented by:

बी ई एम एल लिमिटेड

**BEML LIMITED**

Schedule 'A' Company under Ministry of Defence, Govt. of India

Crawler Dozers From BEML :

**BD50**

**BD65-1**

**BD80**

**BD85**

**BD155**

**BD355**

**BD475**

Form No. BD50/01/2020