

BE75

HYDRAULIC EXCAVATOR

- Efficient Hydraulic System
- Powerful Economical Engine
- Effort-free Operation
- Operator Comfort
- Dual Speed Travel System



Operating Mass	: 7500 kg
Fly Wheel Horse Power (Net)*	: 41.9 kW (57 hp) @ 2000 rpm
Fly Wheel Horse Power (Net)**	: 53kW (71hp) @ 2200 rpm
Bucket capacity	: 0.3 m ³

* Naturally Aspirated Engine

** Engine with Turbocharger

www.bemlindia.in

BE75

HYDRAULIC EXCAVATOR

Salient Features :

Efficient Hydraulic System

Hydraulic system with axial piston pump assures smooth compound work equipment movement and travel. Rugged closed center load sensing hydraulic system.

Powerful economic engine

Diesel engine delivers 57 FHP@2000 rpm (Naturally Aspirated Engine), Diesel Engine delivered 76 HP (Gross)@2200 rpm (Turbo charge engine). A direct injection system for reduced fuel consumption assures high operational economy.

Effort free operation

Hydraulically assisted simple feather touch ergonomically designed controls ensures effort free operations.

Operator Comfort

Specially designed cabin provides plenty of work space and excellent visibility. Remote location of hydraulic tank away from the cabin prevents heating up of the cabin enhancing operator comfort and productivity.

Dual Speed Travel System

Dual Speed hydrostatic drive with counter balance valve and automatic parking brake ensures smooth and safe operation. The lower speed can be used during excavator operation and higher speed during long distance travel for better mobility.



ENGINE

Make	Kirloskar Oil Engines Ltd.	
Model	4R 1040 NA	4R 1040 TC BSIII
Type	Diesel, 4 stroke, Water Cooled, Direct Injection and Naturally Aspirated	Diesel, 4 stroke, Water Cooled. Direct Injection with Turbo Charger,
Power	FHP(Net) 41.9kW (57hp) @2000 rpm	FHP 53kW (71 hp) @2200 rpm
Max Torque	272 Nm (28 Kgm) @1500 rpm	300 Nm (30.59 Kgm) @1500 rpm
No. of cylinders	4, In-line	
Bore & Stroke	∅ 105 mm x 120 mm	
Total displacement	4160 cm ³	
Electrical		
Alternator	24 V, 40A	
Starting Motor	24V	
Battery	2 x 12 V, 75 Ah	

UNDERCARRIAGE

Track frame	Sturdy H bar type centre frame is integrally welded with reinforced box-sections.	
Track Shoe width(STD)	450mm	
No. of shoes	40 each side (Triple Grouser)	
No. of carrier rollers	1 each Side	
No. of track rollers	5 each side	
Ground Pressure	0.031 Mpa (0.32 kg/cm ²)	

SWING SYSTEM

Type	Planetary gear reduction with built in automatic break for swing lock.	
Max Swing Speed	11.8 rpm	
Swing Circle	internal gear and pinion, immersed in grease	
Reduction Ratio	142.348	
Tail Swing radius	1830 mm	

CONTROLS

Work Attachment	Hand operated joy stick pilot controls with accumulator sytem for smooth safe operation	
Travel	Two foot pedals cum hand levers operated pilot control valves for forward / reverse travel and steering	

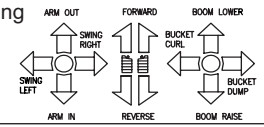

INDICATORS/ALARM/GAUGES

Indicators for alternator charge. Alarm for low engine pressure. Gauges for fuel level, hour meter, water temperature and hydraulic oil level, sight gauge and FM radio, fan

REFILL CAPACITY (Coolant & Lubricant)

System	Capacity (liters)
Fuel Tank	122
Radiator	10
Engine	9.5
Final Drive each side	0.8
Hydraulic Tank	60

STANDARD EQUIPMENT

Boom (3710 mm), Std arm (1650 mm), Std. Bucket (0.3 m³, SAE heaped), starting motor, alternator, batteries, suction type fan, dry type air cleaner, horse power summation hydraulic system, 450 mm triple grouser shoes, hydraulic track adjuster, counter weight, hydrostatic drives, pilot pressure controls, all weather steel cabin (with safety glass windows, lockable door, wiper, electric horn, cabin lamp and adjustable seat with reclining device), rear view mirror, ash tray, portable fire extinguisher, front light & tool kit, Blade attachment for light dozing and leveling operations.

OPTIONAL ACCESSORIES / ATTACHMENTS / BUCKETS

Hydraulic Rock Breaker, Hard Faced Bucket, Trenching Bucket, Cabin front guard, FOPS ditch cleaning Bucket, weed Buckets, Trapezoidal Bucket, Ripper, Short Boom (2650mm).



HYDRAULIC SYSTEM

System Capacity (Liters): 100

Hydraulic Pumps

Main

Type	Variable displacement axial piston pump
Max. oil flow	144 + 72 l/min @ 2000 rpm

Hydraulic Motors

Travel	2 Nos. of two speed axial piston motors with built-in counter balance valves
Swing	1 no. axial piston motor

Control Valves

Type	Main	Compact pilot operated load sensing 8 spool valve
Relief valve settings Mpa (kg/cm ²)	Work Attachment (Boom, arm & bucket) Swing circuit Travel circuit	24.5 (250)
		12.5 (130)
		24.5 (250)

Hydraulic Cylinders

Type	Double acting piston	
	Qty	Bore x Stroke(mm)
Boom	1	∅ 120 x 830
Arm	1	∅ 100 x 885
Bucket	1	∅ 90x 685



DRIVES & BRAKES

Drive Type	Two speed hydrostatic with axial piston motor and planetary reduction gear box for each track
Travel and Steering	Forward/reverse travel and steering actuated with either hand levers of foot pedals. Independent drive to each track enables machine to make a pivot turn in either direction.
Max. Draw bar pull	55.7 kN (5680 kg)
Max Travel Speeds	1) 2.6 km/h - working 2) 4.4 km/h - Transport
Counter Balance Valve	Counter balance valve fitted on each hydraulic motors acts as hydraulic brake. This also prevents possible over speeding in down gradient
Brakes	Oil disc type, spring applied hydraulically released brakes. The brakes are automatically released when pedals are operated for travel.



BACKHOE BUCKET

Bucket Capacity (m ³) (SAE heaped)	0.3
Bucket width (mm) without side cutters	740
Bucket width (mm) with side cutters	920
Bucket weight (kg)	
Without side cutters	220
With side cutters	244
No. of bucket teeth	4



Working Range and Digging Forces

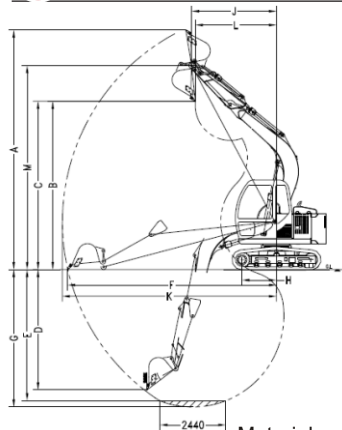

Description Working Range (mm)	Standard Arm (1650) mm
A. Max digging height	7120
B. Max dumping height	4995
C. Max bucket loading clearance	5000
D. Max vertical wall digging depth	3580
E. Max digging depth of cut for 2440 mm level bottom	3775
F. Max digging reach at ground level	6225
G. Max. Digging depth	4090
H. Min. reach at ground reference plane	818
J. Reach at Max. Height	2705
K. Max reach	6385
L. Reach to bucket pin center at Max. Height	2530
M. Max. Bucket hinge pin height	6065
FORCES kN(kgf)	
Bucket digging force	48.3 (4923)
Arm crowd force	37.4 (3802)

Material and specifications are subject to change without notice, Illustrations may include optional equipment & accessories



SAFETY

- Built-in swing brake and hydraulic swing lock ensure safety during along distance travel and transportation.
- Horn
- Automatic parking brake
- Relief valves and safety valves for hydraulic system protection.
- Counter balance valves in travel motors to avoid possible over speeding in down gradient.
- Accumulator in pilot line to bring down the work attachment to a safer position in the absence of engine power.
- Hydraulic filters for protection of hydraulic system against oil contamination.
- Mechanical safety levers for locking hydraulic system controls.



FILTER SYSTEM

ENGINE

Lub Oil	Paper type
Fuel	Pre and Micro
Air	Double element dry type with pre cleaner
Hydraulic System	Return line filter



MASS (kg)

Operating Mass 7500

(Approximate) (Including Boom (3710 mm) Std. Arm (1650 mm), Std. Bucket (0.3m³, SAE Heaped), Operator, Lubricant, coolant, filled fuel tank and hydraulic tank.



Dozing Blade Dimensions (mm)

B1 - Cutting edge to Rib pin center Distance	1321
B2 - Digging depth for ground level	436
B3 - Vertical lift from ground level	285
B4 - Blade height	455
B5 - Overall width	2250



DIMENSIONS (mm)

A-Overall length / B - Width	5850 / 2280
C-Overall height (top of boom)/ D-Cab	2615 / 2495
E-Track length on ground / K-height	2060 / 680
F-Track gauge / T-Width	1700 / 450
G-Min ground clearance / J-Cwt	405 / 760
H-Tail Swing Radius	1830
L- Crawler overall length	2645
M-Sprocket axis to axis rotation	1030
S-height upto Engine Hood	1865
N-Cab width / P-Length / R- Height	940 / 1590 / 1615

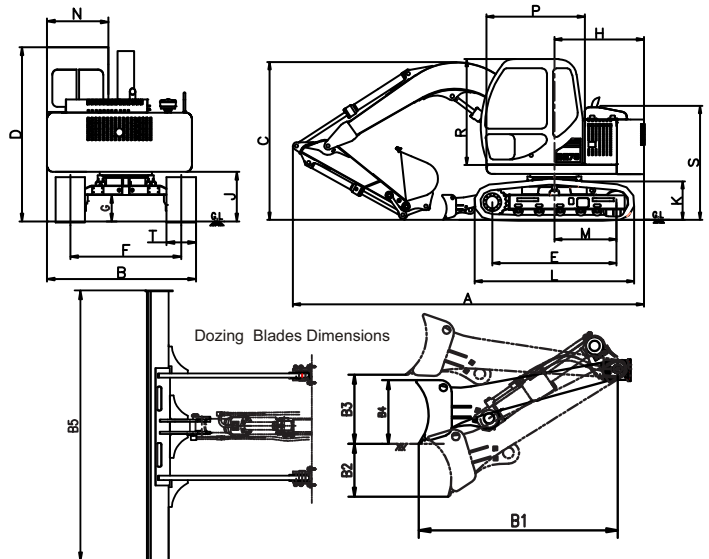

बी ई एम एल लिमिटेड

BEML LIMITED

Schedule 'A' Company under Ministry of Defence, Govt. of India

Business Network

Corporate Office

BEML Soudha, 23/1, 4th Main,
S.R. Nagar, Bangalore – 560 027

T +91 80 22963240, 22963250

F +91 80 22963278/516/280/164

E-mail: office@cpd.beml.co.in
corpcomm@beml.co.in

International Business Division

Flat No. E,F,G, H, 'Vandana' 11th Floor,
11, Tolstoy Marg, Connaught Place
New Delhi – 110 001

T + 91 11 23316500
F + 91 11 23325085

E-mail: office@export.beml.co.in

Marketing Division

5th Floor, Unity Building,
J.C. Road, Bangalore – 560 002

T + 91 80 22963501/02/07/510/540

F + 91 80 22963541

E-mail: m@beml.co.in
mmd@beml.co.in

REGIONAL OFFICES

Bangalore

3rd Floor, Unity Building, J. C. Road,
Bangalore - 560 002
Karnataka

T +91 80 2296 3524
T +91 97413 51588
E-mail: mg@beml.co.in

Bilaspur

1-A, Industrial Area, Sector-C, Sirgitti,
Bilaspur - 495 223.
Chhattisgarh

T + 91 7752 252745, 252598
F + 91 7752 252065
E-mail: mv@beml.co.in

Neyveli

F-4, Dr. Rajendraprasad Road,
Block-27, Neyveli, - 607 803
Tamil Nadu

T/F + 91 4142 268517
T + 91 4142 265517 / 229392
E-mail: ma@beml.co.in

Dhanbad

Mouza - Kangalo, Amaghata,
Govindpur, KG Ashram Post, Dhanbad
Jharkhand - 828 109

T + 91 94711 92023
E-mail: mf@beml.co.in

Hyderabad

3-6-114, Street No.18, Himayat Nagar,
Hyderabad - 500 029
Telangana

T + 91 40 2322 7032 / 94907 93117
F + 91 40 23221794
E-mail: hyderabad@rm.beml.co.in

Kolkata

35/1A, Taratala Road,
Kolkata - 700 088.
West Bengal

T + 91 33 2401 5286 / 87 / 98 / 99
F + 91 33 2401 5288
E-mail: kolkata@rm.beml.co.in

Mumbai

32A, Bazar Road,
Near Jain Mandir, Bandra (West), Mumbai,
Maharashtra - 400 050

T + 91 22 26431875 / 26435875
F + 91 22 26423928
E-mail: mumbai@rm.beml.co.in

Nagpur

No 33, Cement Road,
Shivaji Nagar,
Nagpur - 440 010, Maharashtra.

T + 91 712 2248435 / 2248343
F + 91 712 2249997
E-mail: nagpur@rm.beml.co.in

New Delhi

Flat E,F,G,H, 'Vandana', 11th Floor,
11, Tolstoy Marg, Connaught Place,
New Delhi - 110 001

T + 91 11 2344 3511 / 3528 / 2331 6500
F + 91 11 2332 5085
E-mail: nlm@rm.beml.co.in

Ranchi

206/D-1, Bhagirathi, (Behind NCC Campus)
Rameshwaram Colony, Bariatu Road,
Ranchi, Jharkhand - 834 009

T + 91 651 2540710 / 94311 08531
E-mail: ranchi@rm.beml.co.in

Sambalpur

BEML Complex, NH-6, Panchagachhia,
Baraipalli Post, Sambalpur 768 006
Odisha.

T + 91 663 2521604 / 2521389
E-mail: mb@beml.co.in

Singrauli

PB No. 5, Jhingurdha Colliery,
Singrauli - 486 889
Madhya Pradesh.

T + 91 7805 272668 / 272318
F + 91 7805 272282
E-mail: singrauli@rm.beml.co.in

ACTIVITY CENTRES

Bhopal

Ground Floor, Hall No.1, Chittod Complex, Zone-1,
Maharanapratap Nagar (MP Nagar), Bhopal - 462 011

T + 91 755 2550711 / 8989459753

Panjim

BEML Limited, 5/4, Victor Building, Fontanhas, Mala,
Panjim - 403 001, Goa

T +91 832 2225135 / 77986 87178
E-mail: goa@rm.beml.co.in

Itanagar

C/o. Tobom Riba, H-Sector, Papum
Itanagar – 791 113, Arunachal Pradesh

T + 91 94029 34205 / 88372 15852
E-mail: mcgi@beml.co.in

Kochi

No. 39/2122, Chittod Road, Ernakulam South,
Kochi – 682 016

T + 91 484 2375138
E-mail: kochi@rm.beml.co.in

Maihar

Maihar, Madhya Pradesh

Mob: +91 79875 53768

Silapathar

Silapathar: Surya Vatika, Amritpur, Silapathar, Assam - 787 059

T +91 95311 29059

Visakhapatnam

No. 8-45-11, 4th Lane, Vidyannagar China Waltair Colony
Visakhapatnam - 530 003, Andhra Pradesh

T/F +91 891 2754608 / 83320 54590
E-mail: vizag@rm.beml.co.in

DISTRICT OFFICES

Ahmedabad

99/100, BEML HOUSE, 2nd Street,
Azad Society, Ambawadi,
Ahmedabad - 380 015, Gujarat

T + 91 79 26445523 / 94264 13620
F + 91 79 26423950
E-mail: ahmedabad@rm.beml.co.in

Asansol

3, Burnpur Road,
Asansol - 713 304
West Bengal

T + 91 341 2252480
F + 91 341 2250601
E-mail: asansol@rm.beml.co.in

Bacheli

Behind Central Stores of NMDC Ltd.,
Depot 5, Bacheli - 494 553.
Chhattisgarh

T/F + 91 7857 230005
E-mail: bacheli@rm.beml.co.in

Bhilai

Room no 22/C, BSP Expansion Building,
Near Ispat Bhavan, Bhilai 490 001, Chhattisgarh

T + 91 788 2223880
F + 91 788 2221652
E-mail: mnboffice@beml.co.in

Bhubaneswar

252/A, Lewis Road
Bhubaneswar - 751 014
Odisha

T + 91 674 2434427 / 99373 83950
E-mail: mbb@beml.co.in

Chandrapur

Mamidwar, Tiles Factory Compound
Chugus Road, Padoli
Chandrapur - 442 406 Maharashtra

T + 91 7172 287230
F + 91 7172 287560
E-mail: mnc@beml.co.in

Chennai

Flat No. 10, Supriya Estates,
No.3, Sterling Road, Nungambakkam,
Chennai - 600 034, Tamil Nadu,

T + 91 44 28220844
F + 91 44 28257319
E-mail: chennai@rm.beml.co.in

Guwahati

No.11, Ward 43, Hengrabari Road,
Ganesh Puri, Dispur,
Guwahati - 781 006 Assam

T + 91 361 2232966
F + 91 361 2232967
E-mail: guwahati@rm.beml.co.in

Hospet

No.1431, Manjunatha Complex,
Bhagat Singh Nagar, Opp. KSSIDC Indl. Estate,
Dam Road, Hospet - 583 203, Karnataka

T/F + 91 8394 230172
E-mail: hospet@rm.beml.co.in

Jammu

62C, Block D/C, Gandhi Nagar,
Jammu tawi - 180 004
Jammu and Kashmir

T + 91 191 2459 437
F + 91 191 2430 447
E-mail: mlj@beml.co.in

Kothagudem

Old Project Planning Department,
Near SCCL Corporate Office,
Kothagudem - 507 101, Telangana

T + 91 8744 245572
F + 91 8744 245530
E-mail: kothagudem@rm.beml.co.in

Leh

174-B, (Near Royal Enfield Showroom),
Housing Colony, Leh, Ladakh -194 101

T + 91 1982 258828 / 94198 71008
E-mail: ml@beml.co.in

Ramagundam

Near SCCL TTC, Jawahar Nagar,
Behind CISF Camp, Godavarikhani - 505 209.
Peddapalli Dist., Telangana

T + 91 8728 248299 / 94408 58441
E-mail: mhr@beml.co.in

Udaipur

20-B, Uchhab Bhavan, Bedla Road,
Fatehpura, Udaipur - 313 001.
Rajasthan

T + 91 294 2452054
E-mail: mwu@beml.co.in

www.bemlindia.in

Represented by:

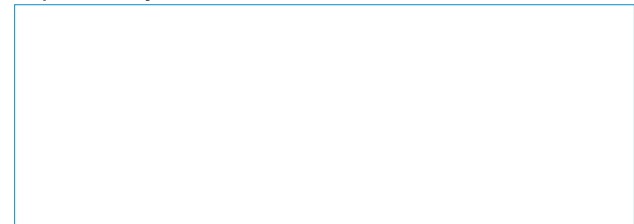

Form No. BE75/01/2020

बी ई एम एल लिमिटेड

BEML LIMITED

Schedule 'A' Company under Ministry of Defence, Govt. of India

Hydraulic Excavators

BE75

BE220G

BE300LC

BE450LC

BE700

BE1000-1

BE1000E-1

BE1800D

BE1800E