

BE220

G

HYDRAULIC EXCAVATOR



- Efficient Hydraulic System
- Powerful Economical Engine
- Effort-free Operation
- Maximum working performance
- Easy maintenance
- Operator Comfort



Operating Mass	: 22,800 kg
Flywheel Horse Power (Net)	: 110 kW (148 hp) @ 2000 rpm
Bucket capacity (SAE/ISO heaped)	: 0.44 - 1.26 m ³

www.bemlindia.in

BE220 **G** HYDRAULIC EXCAVATOR

Salient Features :

Efficient Hydraulic System

Positive Control main pump hydraulic system with advanced optimum hydraulic control system assures easy & smooth independent and simultaneous compound functions. The horse power summation feature makes full use of engine output power for maximum productivity with faster cycle time. The positive control pump, tandem-parallel circuit featuring boom and arm regeneration functions and advanced control valve with load sensing feature reduces the hydraulic loss during idling and increases oil flow in direct proportion to joystick movement for precise control.

Powerful economic engine

BEML diesel engine BS6D105-1 delivers 110 kW (148hp). A direct injection system ensures reduced fuel consumption and assures high operational economy. The turbo charger allows engine to attain high performance even on high altitude job sites.

Effort free operation

Work equipment controls are simple and light touch due to the hydraulically assisted control system.

Maximum working performance

2 mode selection switch provided in the operator cabin can be used for high excavation efficiency. "S" Mode for standard working condition and better fuel efficiency and "H" Mode for heavy duty application.

Easy maintenance

Centralized monitoring system within the operator's cab allows fast daily checks and also keeps the operator constantly informed of any abnormality during operation.

Operator Comfort

Specially designed cab provides plenty of work space and excellent visibility.

ENGINE

Make Model	BEML BS6D105-1
Type	Diesel, 4 stroke, Water Cooled, turbo charged, direct injection
Bore & Stroke	∅ 105 mm x 125 mm
Piston displacement	6.494 l (6494 cc)
Net horsepower	110 kW (148 fhp) @ 2000 rpm
No. of cylinders	6, In-line
Governor	All speed, mechanical
Electricals	
Alternator	24 V, 45A
Starting Motor	24V, 4.5 kW
Battery	2 x 12 V, 150 Ah

DRIVES & BRAKES

Steering Control	Either hand levers or foot pedals
Drives	
Drive Type	Compact design with planetary reduction with inbuilt counter balance valve and anti shock valve for smooth operation
Max. Drawbar pull	158 kN (16,145 kg)
Max. travel speed	3.0 kmph
Travel / Parking	Hydraulic wet Brake coupled to motor
Brake	Spring applied and hydraulically released oil disc brakes. Travel motors are equipped with counter balance valve which regulates speed when making descents.

UNDERCARRIAGE

Track frame	H bar type centre frame is integrally welded with reinforced box-section track frame
Shoe width	610 mm
No. of shoes	47 each side
No. of carrier rollers	2 each Side
No. of track rollers	8 each side
Ground Pressure	48 kPa (0.49 kg/cm ²)

STANDARD EQUIPMENT

Dry type air cleaner	PPC hydraulic control
610 mm track shoe	Hydraulic track adjuster
Fully hydrostatic drive	Suction fan
Radiator & oil cooler	Front light
Electric horn	Counter weight
Rear view mirror	Electronic monitoring system
All weather steel cab	Tool kit
(with safety glass windows, lockable door, window wiper, room lamp and adjustable seat)	Portable fire extinguisher

OPTIONAL ACCESSORIES / ATTACHMENTS / BUCKETS

Windshield washer
Front windshield protective guard
FOPS
Cabin heater
Air conditioner
High rise cabin
Track shoes (500 mm, 710 mm & 810 mm)
Long arm (3.045 m)
Extra long arm (3.5 m)
Short arm (2.0 m & 2.2 m)
Super long front (for 12.2m & 18.3 m reach)
Trapezoidal bucket (0.5 m ³)
Slope finishing bucket (0.35 m ³)
Ripper bucket (0.56 m ³)
Clamshell bucket (0.6 m ³ & 1.2 m ³)
Super long front bucket (0.64m ³ & 0.44 m ³)
Light duty bucket (1.14 m ³ & 1.26 m ³)
Single shank ripper
Three shank ripper
Hydraulic rock breaker



HYDRAULIC SYSTEM

Type Positive control hydraulic system featuring boom and arm regeneration with summation and two mode selection for optimum utilisation of hydraulic power resulting in improved fuel efficiency

Hydraulic Pumps

Main Pump	Variable displacement axial piston pump
Maximum flow	405 l/min @ 2150 rpm
Pilot pump	1 no. Auxiliary pump

Hydraulic Motors

Travel	2 nos. Axial piston motor
Swing	1 no. Axial piston motor
Relief valve settings	

Implement circuits 31.4 MPa (320 kg/cm²)
(Boom, arm & bucket)

Swing circuits 29.13 MPa (297 kg/cm²)

Travel circuits 31.4 MPa (320 kg/cm²)

Pilot circuits 2.94 - 3.53 MPa (30 - 36 kg/cm²)

Control valves

Type 8 Spool control valve including a spare spool for auxiliary attachment

Hydraulic Cylinders

Type Double acting piston type

Cylinders	No.	Bore x Stroke
Boom	2	130 x 1234 mm
Arm	1	140 x 1628 mm
Bucket	1	130 x 989 mm

COOLANT & LUBRICANT CAPACITY (Refill)

Fuel tank	280.0 l
Radiator	33.0 l
Engine	23.0 l
Final drive each side	3.4 l
Swing drive	6.0 l
Hydraulic tank	150.0 l

SWING SYSTEM

Swing lock	Hydraulic disc brake type
Swing reduction	Spur and planetary reduction
Swing speed	13 rpm
Tail swing radius	2845 mm

DIMENSIONS (mm) (Fig B)

Overall length	10000
Overall width	2990
Overall height (top of boom)	3200
Track length on ground	3445
Track gauge	2380
Ground clearance	440

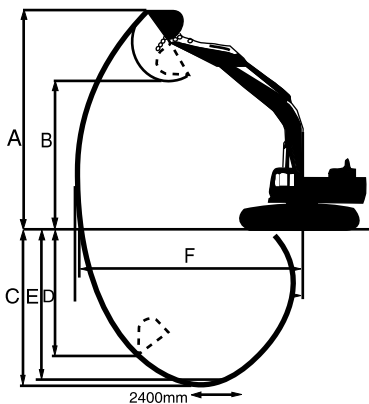

Fig. 'A'

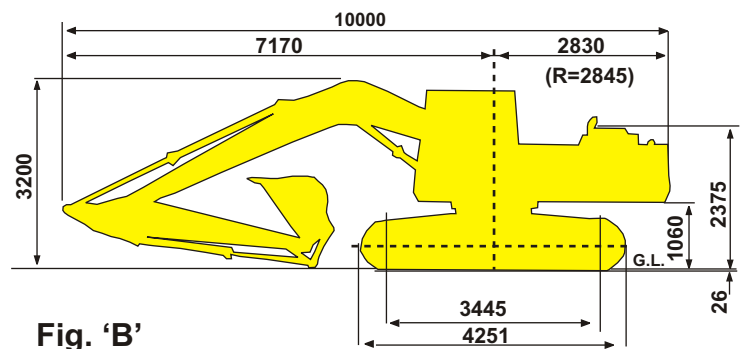
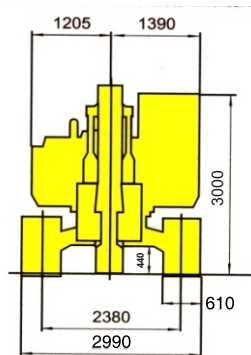

Fig. 'B'

Material and specifications are subject to change without notice, Illustrations may include optional equipment & accessories

GAUGES & INDICATORS

LCD Gauge / Sight Gauge	Fuel gauge, water temperature gauge, engine oil pressure gauge, engine rpm, Hour meter, Hydraulic oil level and temperature gauge.
Indicators & alarms	Hydraulic Oil Level, Engine Oil Level, Battery Charge (indicator), Radiator Water Level, Engine Oil Pressure, Water Temperature

WORKING RANGE (Fig A)

Arm length	3.045m	2.0m	2.2m	2.5m	3.5m
A max. digging height (m)	9.18	8.90	8.93	8.97	9.44
B max. dumping height (m)	6.36	6.10	6.13	6.20	6.61
C max. digging depth (m)	6.70	5.67	5.88	6.17	7.16
D max. vertical wall digging depth (m)	5.76	4.61	5.74	4.97	6.20
E max. Digging depth of cut for 2440 mm level bottom (m)	6.57	5.43	5.67	5.96	7.01
F max. digging reach at ground level (m)	10.00	9.09	9.27	9.51	10.46
Bucket digging force kN (kg)	125 (12700)	125 (12700)	126 (12820)	125 (12700)	125 (12700)
Arm crowd force kN (kg)	100 (10200)	147 (14990)	136 (13905)	120 (12270)	91 (9280)

OPERATING MASS

22800 kg (including 5.85 m boom, 2.5 m arm, 1.0 m³ SAE heaped backhoe bucket, coolant, full fuel tank, Hydraulic tank and operator)

FILTRATION

Engine	Two stage fuel filter with water separator
Air-intake	Dry type, two stage air cleaner with dust evacuator
Hydraulic	One suction strainer, one return line filter and one pilot filter.

BACKHOE BUCKETS

BACKHOE BUCKETS	Narrow bucket		Standard bucket		Light duty bucket	
Bucket Capacity m ³						
SAE heaped	0.44	0.72	1.00	1.14	1.26	
Struck	0.36	0.55	0.75	0.83	0.90	
Bucket width mm						
Without side cutters	600	900	1085	1300	1400	
With side cutters	705	1005	1190	1405	1505	
Bucket Mass kg (with teeth)						
Without side cutters	609	810	776	877	886	
With side cutters	643	844	810	911	920	
No. of bucket teeth	3	3	4	5	5	

बी ई एम एल लिमिटेड

BEML LIMITED

Schedule 'A' Company under Ministry of Defence, Govt. of India

Business Network

Corporate Office

BEML Soudha, 23/1, 4th Main,
S.R. Nagar, Bangalore - 560 027

T +91 80 22963240, 22963250

F +91 80 22963278/516/280/164

E-mail: office@cpd.beml.co.in
corpcomm@beml.co.in

International Business Division

Flat No. E,F,G, H, 'Vandana' 11th Floor,
11, Tolstoy Marg, Connaught Place
New Delhi - 110 001

T + 91 11 23316500
F + 91 11 23325085

E-mail: office@export.beml.co.in

Marketing Division

5th Floor, Unity Building,
J.C. Road, Bangalore - 560 002

T + 91 80 22963501/02/07/510/540

F + 91 80 22963541

E-mail: m@beml.co.in
mmd@beml.co.in

REGIONAL OFFICES

Bangalore

3rd Floor, Unity Building, J. C. Road,
Bangalore - 560 002
Karnataka

T +91 80 2296 3524
T +91 97413 51588
E-mail: mg@beml.co.in

Bilaspur

1-A, Industrial Area, Sector-C, Sirgitti,
Bilaspur - 495 223.
Chhattisgarh

T + 91 7752 252745, 252598
F + 91 7752 252065
E-mail: mv@beml.co.in

Neyveli

F-4, Dr. Rajendraprasad Road,
Block-27, Neyveli, - 607 803
Tamil Nadu

T/F + 91 4142 268517
T + 91 4142 265517 / 229392
E-mail: ma@beml.co.in

Dhanbad

Mouza - Kangalo, Amaghata,
Govindpur, KG Ashram Post, Dhanbad
Jharkhand - 828 109

T + 91 94711 92023
E-mail: mf@beml.co.in

Hyderabad

3-6-114, Street No.18, Himayat Nagar,
Hyderabad - 500 029
Telangana

T + 91 40 2322 7032 / 94907 93117
F + 91 40 23221794
E-mail: hyderabad@rm.beml.co.in

Kolkata

35/1A, Taratala Road,
Kolkata - 700 088.
West Bengal

T + 91 33 2401 5286 / 87 / 98 / 99
F + 91 33 2401 5288
E-mail: kolkata@rm.beml.co.in

Mumbai

32A, Bazar Road,
Near Jain Mandir, Bandra (West), Mumbai,
Maharashtra - 400 050

T + 91 22 26431875 / 26435875
F + 91 22 26423928
E-mail: mumbai@rm.beml.co.in

Nagpur

No 33, Cement Road,
Shivaji Nagar,
Nagpur - 440 010, Maharashtra.

T + 91 712 2248435 / 2248343
F + 91 712 2249997
E-mail: nagpur@rm.beml.co.in

New Delhi

Flat E,F,G,H, 'Vandana', 11th Floor,
11, Tolstoy Marg, Connaught Place,
New Delhi - 110 001

T + 91 11 2344 3511 / 3528 / 2331 6500
F + 91 11 2332 5085
E-mail: nlm@rm.beml.co.in

Ranchi

206/D-1, Bhagirathi, (Behind NCC Campus)
Rameshwaram Colony, Bariat Road,
Ranchi, Jharkhand - 834 009

T + 91 651 2540710 / 94311 08531
E-mail: ranchi@rm.beml.co.in

Sambalpur

BEML Complex, NH-6, Panchagachhia,
Baraipalli Post, Sambalpur 768 006
Odisha.

T + 91 663 2521604 / 2521389
E-mail: mb@beml.co.in

Singrauli

PB No. 5, Jhingurdha Colliery,
Singrauli - 486 889
Madhya Pradesh.

T + 91 7805 272668 / 272318
F + 91 7805 272282
E-mail: singrauli@rm.beml.co.in

ACTIVITY CENTRES

Bhopal

Ground Floor, Hall No.1, Chittod Complex, Zone-1,
Maharanapratap Nagar (MP Nagar), Bhopal - 462 011

T + 91 755 2550711 / 8989459753

Panjim

BEML Limited, 5/4, Victor Building, Fontanhas, Mala,
Panjim - 403 001, Goa

T +91 832 2225135 / 77986 87178
E-mail: goa@rm.beml.co.in

Itanagar

C/o. Tobom Riba, H-Sector, Papum
Itanagar - 791 113, Arunachal Pradesh

T + 91 94029 34205 / 88372 15852
E-mail: mcgi@beml.co.in

Kochi

No. 39/2122, Chittod Road, Ernakulam South,
Kochi - 682 016

T + 91 484 2375138
E-mail: kochi@rm.beml.co.in

Maihar

Maihar, Madhya Pradesh

Mob: +91 79875 53768

Silapathar

Silapathar: Surya Vatika, Amritpur, Silapathar, Assam - 787 059

T +91 95311 29059

Visakhapatnam

No. 8-45-11, 4th Lane, Vidyannagar China Waltair Colony
Visakhapatnam - 530 003, Andhra Pradesh

T/F +91 891 2754608 / 83320 54590
E-mail: vizag@rm.beml.co.in

DISTRICT OFFICES

Ahmedabad

99/100, BEML HOUSE, 2nd Street,
Azad Society, Ambawadi,
Ahmedabad - 380 015, Gujarat

T + 91 79 26445523 / 94264 13620
F + 91 79 26423950
E-mail: ahmedabad@rm.beml.co.in

Asansol

3, Burnpur Road,
Asansol - 713 304
West Bengal

T + 91 341 2252480
F + 91 341 2250601
E-mail: asansol@rm.beml.co.in

Bacheli

Behind Central Stores of NMDC Ltd.,
Depot 5, Bacheli - 494 553.
Chhattisgarh

T/F + 91 7857 230005
E-mail: bacheli@rm.beml.co.in

Bhilai

Room no 22/C, BSP Expansion Building,
Near Ispat Bhavan, Bhilai 490 001, Chhattisgarh

T + 91 788 2223880
F + 91 788 2221652
E-mail: mnboffice@beml.co.in

Bhubaneswar

252/A, Lewis Road
Bhubaneswar - 751 014
Odisha

T + 91 674 2434427 / 99373 83950
E-mail: mbb@beml.co.in

Chandrapur

Mamidwar, Tiles Factory Compound
Chugus Road, Padoli
Chandrapur - 442 406 Maharashtra

T + 91 7172 287230
F + 91 7172 287560
E-mail: mnc@beml.co.in

Chennai

Flat No. 10, Supriya Estates,
No.3, Sterling Road, Nungambakkam,
Chennai - 600 034, Tamil Nadu,

T + 91 44 28220844
F + 91 44 28257319
E-mail: chennai@rm.beml.co.in

Guwahati

No.11, Ward 43, Hengrabari Road,
Ganesh Puri, Dispur,
Guwahati - 781 006 Assam

T + 91 361 2232966
F + 91 361 2232967
E-mail: guwahati@rm.beml.co.in

Hospet

No.1431, Manjunatha Complex,
Bhagat Singh Nagar, Opp. KSSIDC Indl. Estate,
Dam Road, Hospet - 583 203, Karnataka

T/F + 91 8394 230172
E-mail: hospet@rm.beml.co.in

Jammu

62C, Block D/C, Gandhi Nagar,
Jammu tawi - 180 004
Jammu and Kashmir

T + 91 191 2459 437
F + 91 191 2430 447
E-mail: mlj@beml.co.in

Kothagudem

Old Project Planning Department,
Near SCCL Corporate Office,
Kothagudem - 507 101, Telangana

T + 91 8744 245572
F + 91 8744 245530
E-mail: kothagudem@rm.beml.co.in

Leh

174-B, (Near Royal Enfield Showroom),
Housing Colony, Leh, Ladakh -194 101

T + 91 1982 258828 / 94198 71008
E-mail: ml@beml.co.in

Ramagundam

Near SCCL TTC, Jawahar Nagar,
Behind CISF Camp, Godavarikhani - 505 209.
Peddapalli Dist., Telangana

T + 91 8728 248299 / 94408 58441
E-mail: mhr@beml.co.in

Udaipur

20-B, Uchhab Bhavan, Bedla Road,
Fatehpura, Udaipur - 313 001.
Rajasthan

T + 91 294 2452054
E-mail: mwu@beml.co.in

www.bemlindia.in

Represented by:

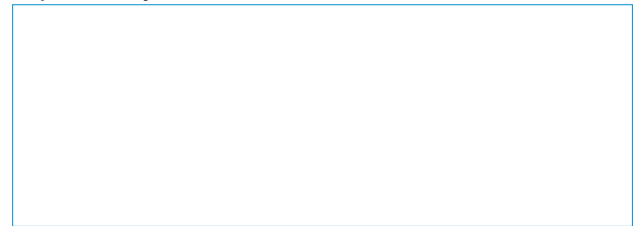

बी ई एम एल लिमिटेड

BEML LIMITED

Schedule 'A' Company under Ministry of Defence, Govt. of India

Hydraulic Excavators

BE75

BE220G

BE300LC

BE450LC

BE700

BE1000-1

BE1000E-1

BE1800D

BE1800E

Form No. BE220G/01/2020