

BL200-1

FRONT END LOADER

- More Productivity
- Powerful & BSIII Compliant Engine
- Easy Manueverability
- Easy Maintenance
- More Operator Comfort
- More Reliability



Gross Power : 99 kW (133 hp) @ 2300 r/min
(as per ISO: 1585)

Bucket Capacity : 1.7 m³

BL200-1 FRONT END LOADER

Salient Features :

- H6ETIC3RU23-BS III Ashok Leyland Turbo-charged engine for fuel economy and generous HP to weight ratio for wide range of loading applications complying with Bharat stage III emission norms.
- 2F-1R Powershift transmission for smooth and responsive shift for instant speed and directional changes.
- Pilot operated hydraulic system offers effortless fine control of Bucket through joy stick.
- Smooth Orbitrol Steering system provide excellent maneuverability during gradual and sharp turns with enhanced operator comfort.
- Engine and Transmission are mounted on anti-vibration rubber cushions to isolate vibration and to reduce noise levels.



ENGINE

Make	Ashok Leyland
Model	H6ETIC3RU23-BS III
Type	Diesel, 4-stroke Water-cooled, turbo-charged, direct injection.
Gross Power	99 kW (133 hp) @ 2300 r/min. (as per ISO: 1585)
No. of Cylinders	6, inline
Cooling system	Water pump 45 GPM Twin port upward
Lubricating system	1 in 1 sump, Rocker cover with oil filler arrangement, heavy duty plate type oil cooler.
Control System	Twin lever for throttle connection
Electrical System	24V/4.5 kW Lucas starter motor.



TRANSMISSION

Model	AVTEC TT2221 - 1
Torque converter type	twin turbine, integral
Transmission	
Type	Power shift
No. of Gears	2F / 1R



STEERING

Type	Fully hydrostatic power steering system independent of engine speed with Orbitrol type Steering
Relief pressure setting	175 bar (17.5 Mpa)



AXLES

Type	Both axles fully floating, planetary type final drive. Front axle rigid mounted & Rear axle oscillating type with limited slip differential.
------	--



SPEED

	AVTEC TT2221 - 1	
Gear	1st	2nd
Forward (kmph)	6	36
Reverse (kmph)	22	



BRAKES

Service brake	Four wheel, internal wet multiple disc brakes.
Parking Brake	Mechanical, Dry disc, on transmission output shaft



STANDARD EQUIPMENT

1.7 m³ (STD. Bucket)

OPTIONAL ATTACHMENTS

1.2 m³, 1.5 m³, 2.3 m³, 2.5 m³, 3.0 m³, 3.2 m³ BUCKET
Multipurpose Bucket, Dozer Blade

Optional Fittings :

Centralised Auto Lubrication, AFDSS, Rear View Camera

INSTRUMENTATION

Dash Board	Aesthetically designed instrument panel for better readability.
Gauges / Warning	Backlit electrical gauges & Audio visual warning system
Wire harness	Newly designed wire harness with blade fuse links, drip proof connectors and bicolour coded cables to improve safety and reliability of electrical system.

HYDRAULIC SYSTEM

Hydraulic pump

Type	Gear pump
Capacity	155 l/min @ engine rated speed
Relief pressure	210 bar (21.0 MPa)

Hydraulic cylinder	Qty	Bore x Stroke
Lift cylinder	2	∅120 mm x 700 mm
Dump cylinder	1	∅ 130 mm x 474 mm
Steering cylinder	2	∅ 70 mm x 460 mm

Controls Through hydraulic Joystic, pilot operated

Pilot Pressure : Relief set at 35 bar

COOLANT & LUBRICANT REFILL CAPACITY

System	Capacity (litre)
Hydraulic	81
Fuel tank	170

TYRES

Type	14 x 25, 20PR, (L3), TUBELESS TYRE
------	------------------------------------

CABIN

Cabin Steel Cabin, spacious, comfortable & high visibility cabin fitted with 2 doors and 2 side windows, sliding rear window and safety glass all around.

LOADER PERFORMANCE

Bucket capacity (SAE rated)	1.7m ³
Max. Dumping clearance	2800 mm
Operating height (fully raised)	4775 mm
Max. Digging depth	250 mm
Bucket dumping angle	45°
Maximum traction force	9880 kg
Break out Force	9900 kg
Articulation	38° each side

OPERATING MASS

Operating Mass	10500 kg (including Cabin)
Payload	3000 kg

FILTRATION

Engine	Replaceable Spin-on type filter for lubrication as well as for fuel line
Transmission	One magnetic oil strainer and one replaceable element bypass filter is provided
Hydraulic System	Magnetic plug & replaceable element type filter is provided

BUCKET CAPACITY

SI No.	Density of the Material	Bucket Size
	Handled (kg/m ³)	(in m ³)
1.	2500 - 2600	1.2
2.	2000 - 2100	1.5
3.	1700 - 1800	1.7 (Std.)
4.	1300 - 1350	2.3
5.	1200 - 1250	2.5
6.	1000 - 1025	3.0
7.	925 - 975	3.2

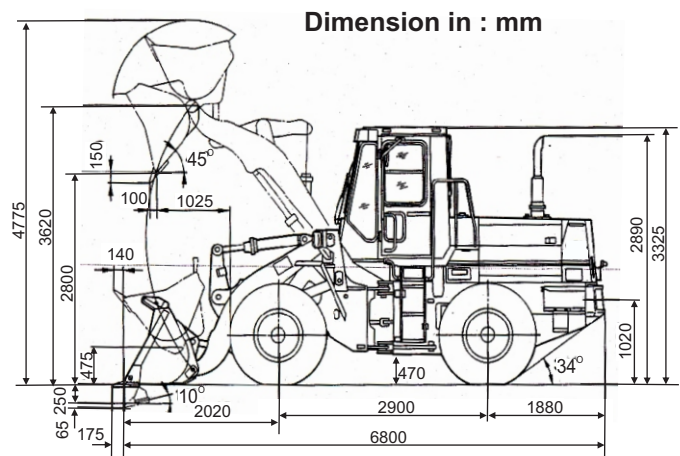
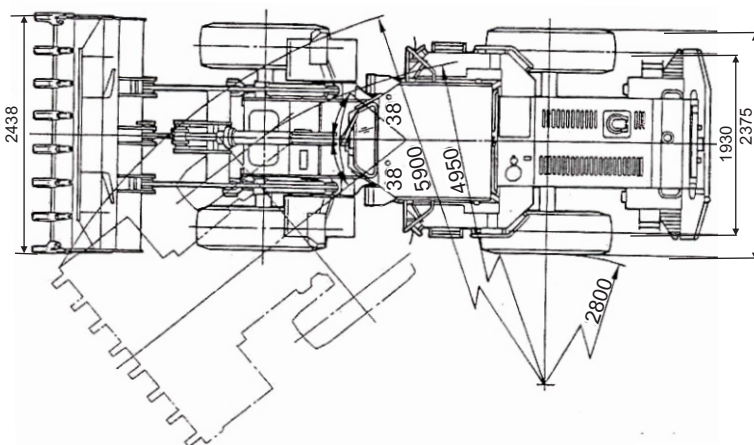

Material and specifications are subject to change without notice, Illustrations may include optional equipment & accessories

बी ई एम एल लिमिटेड

BEML LIMITED

Schedule 'A' Company under Ministry of Defence, Govt. of India

Business Network

Corporate Office

BEML Soudha, 23/1, 4th Main,
S.R. Nagar, Bangalore – 560 027

T +91 80 22963240, 22963250

F +91 80 22963278/516/280/164

E-mail: office@cpd.beml.co.in
corpcomm@beml.co.in

International Business Division

Flat No. E,F,G, H, 'Vandana' 11th Floor,
11, Tolstoy Marg, Connaught Place
New Delhi – 110 001

T + 91 11 23316500
F + 91 11 23325085

E-mail: office@export.beml.co.in

Marketing Division

5th Floor, Unity Building,
J.C. Road, Bangalore – 560 002

T + 91 80 22963501/02/07/510/540

F + 91 80 22963541

E-mail: m@beml.co.in
mmd@beml.co.in

REGIONAL OFFICES

Bangalore

3rd Floor, Unity Building, J. C. Road,
Bangalore - 560 002
Karnataka

T +91 80 2296 3524
T +91 97413 51588
E-mail: mg@beml.co.in

Bilaspur

1-A, Industrial Area, Sector-C, Sirgitti,
Bilaspur - 495 223.
Chhattisgarh

T + 91 7752 252745, 252598
F + 91 7752 252065
E-mail: mv@beml.co.in

Neyveli

F-4, Dr. Rajendraprasad Road,
Block-27, Neyveli, - 607 803
Tamil Nadu

T/F + 91 4142 268517
T + 91 4142 265517 / 229392
E-mail: ma@beml.co.in

Dhanbad

Mouza - Kangalo, Amaghata,
Govindpur, KG Ashram Post, Dhanbad
Jharkhand – 828 109

T + 91 94711 92023
E-mail: mf@beml.co.in

Hyderabad

3-6-114, Street No.18, Himayat Nagar,
Hyderabad - 500 029
Telangana

T + 91 40 2322 7032 / 94907 93117
F + 91 40 23221794
E-mail: hyderabad@rm.beml.co.in

Kolkata

35/1A, Taratala Road,
Kolkata - 700 088.
West Bengal

T + 91 33 2401 5286 / 87 / 98 / 99
F + 91 33 2401 5288
E-mail: kolkata@rm.beml.co.in

Mumbai

32A, Bazar Road,
Near Jain Mandir, Bandra (West), Mumbai,
Maharashtra - 400 050

T + 91 22 26431875 / 26435875
F + 91 22 26423928
E-mail: mumbai@rm.beml.co.in

Nagpur

No 33, Cement Road,
Shivaji Nagar,
Nagpur - 440 010, Maharashtra.

T + 91 712 2248435 / 2248343
F + 91 712 2249997
E-mail: nagpur@rm.beml.co.in

New Delhi

Flat E,F,G,H, 'Vandana', 11th Floor,
11, Tolstoy Marg, Connaught Place,
New Delhi - 110 001

T + 91 11 2344 3511 / 3528 / 2331 6500
F + 91 11 2332 5085
E-mail: nlm@rm.beml.co.in

Ranchi

206/D-1, Bhagirathi, (Behind NCC Campus)
Rameshwaram Colony, Bariatu Road,
Ranchi, Jharkhand - 834 009

T + 91 651 2540710 / 94311 08531
E-mail: ranchi@rm.beml.co.in

Sambalpur

BEML Complex, NH-6, Panchagachhia,
Baraipalli Post, Sambalpur 768 006
Odisha.

T + 91 663 2521604 / 2521389
E-mail: mb@beml.co.in

Singrauli

PB No. 5, Jhingurdha Colliery,
Singrauli - 486 889
Madhya Pradesh.

T + 91 7805 272668 / 272318
F + 91 7805 272282
E-mail: singrauli@rm.beml.co.in

ACTIVITY CENTRES

Bhopal

Ground Floor, Hall No.1, Chittod Complex, Zone-1,
Maharanapratap Nagar (MP Nagar), Bhopal - 462 011

T + 91 755 2550711 / 8989459753

Panjim

BEML Limited, 5/4, Victor Building, Fontanhas, Mala,
Panjim - 403 001, Goa

T +91 832 2225135 / 77986 87178
E-mail: goa@rm.beml.co.in

Itanagar

C/o. Tobom Riba, H-Sector, Papum
Itanagar – 791 113, Arunachal Pradesh

T + 91 94029 34205 / 88372 15852
E-mail: mcgi@beml.co.in

Kochi

No. 39/2122, Chittod Road, Ernakulam South,
Kochi – 682 016

T + 91 484 2375138
E-mail: kochi@rm.beml.co.in

Maihar

Maihar, Madhya Pradesh

Mob: +91 79875 53768

Silapathar

Silapathar: Surya Vatika, Amritpur, Silapathar, Assam - 787 059

T +91 95311 29059

Visakhapatnam

No. 8-45-11, 4th Lane, Vidyannagar China Waltair Colony
Visakhapatnam - 530 003, Andhra Pradesh

T/F +91 891 2754608 / 83320 54590
E-mail: vizag@rm.beml.co.in

DISTRICT OFFICES

Ahmedabad

99/100, BEML HOUSE, 2nd Street,
Azad Society, Ambawadi,
Ahmedabad - 380 015, Gujarat

T + 91 79 26445523 / 94264 13620
F + 91 79 26423950
E-mail: ahmedabad@rm.beml.co.in

Asansol

3, Burnpur Road,
Asansol - 713 304
West Bengal

T + 91 341 2252480
F + 91 341 2250601
E-mail: asansol@rm.beml.co.in

Bacheli

Behind Central Stores of NMDC Ltd.,
Depot 5, Bacheli - 494 553.
Chhattisgarh

T/F + 91 7857 230005
E-mail: bacheli@rm.beml.co.in

Bhilai

Room no 22/C, BSP Expansion Building,
Near Ispat Bhavan, Bhilai 490 001, Chhattisgarh

T + 91 788 2223880
F + 91 788 2221652
E-mail: mnboffice@beml.co.in

Bhubaneswar

252/A, Lewis Road
Bhubaneswar - 751 014
Odisha

T + 91 674 2434427 / 99373 83950
E-mail: mbb@beml.co.in

Chandrapur

Mamidwar, Tiles Factory Compound
Chugus Road, Padoli
Chandrapur - 442 406 Maharashtra

T + 91 7172 287230
F + 91 7172 287560
E-mail: mnc@beml.co.in

Chennai

Flat No. 10, Supriya Estates,
No.3, Sterling Road, Nungambakkam,
Chennai - 600 034, Tamil Nadu,

T + 91 44 28220844
F + 91 44 28257319
E-mail: chennai@rm.beml.co.in

Guwahati

No.11, Ward 43, Hengrabari Road,
Ganesh Puri, Dispur,
Guwahati - 781 006 Assam

T + 91 361 2232966
F + 91 361 2232967
E-mail: guwahati@rm.beml.co.in

Hospet

No.1431, Manjunatha Complex,
Bhagat Singh Nagar, Opp. KSSIDC Indl. Estate,
Dam Road, Hospet - 583 203, Karnataka

T/F + 91 8394 230172
E-mail: hospet@rm.beml.co.in

Jammu

62C, Block D/C, Gandhi Nagar,
Jammu tawi - 180 004
Jammu and Kashmir

T + 91 191 2459 437
F + 91 191 2430 447
E-mail: mlj@beml.co.in

Kothagudem

Old Project Planning Department,
Near SCCL Corporate Office,
Kothagudem - 507 101, Telangana

T + 91 8744 245572
F + 91 8744 245530
E-mail: kothagudem@rm.beml.co.in

Leh

174-B, (Near Royal Enfield Showroom),
Housing Colony, Leh, Ladakh -194 101

T + 91 1982 258828 / 94198 71008
E-mail: ml@beml.co.in

Ramagundam

Near SCCL TTC, Jawahar Nagar,
Behind CISF Camp, Godavarikhani - 505 209.
Peddapalli Dist., Telangana

T + 91 8728 248299 / 94408 58441
E-mail: mhr@beml.co.in

Udaipur

20-B, Uchhab Bhavan, Bedla Road,
Fatehpura, Udaipur - 313 001.
Rajasthan

T + 91 294 2452054
E-mail: mwu@beml.co.in

www.bemlindia.in

Represented by:



बी ई एम एल लिमिटेड

BEML LIMITED

Schedule 'A' Company under Ministry of Defence, Govt. of India

Loader From BEML :

BL200-1

BL30-1

BL40

Form No. BL200-1/01/2020